

A
SCALE: 1 : 5

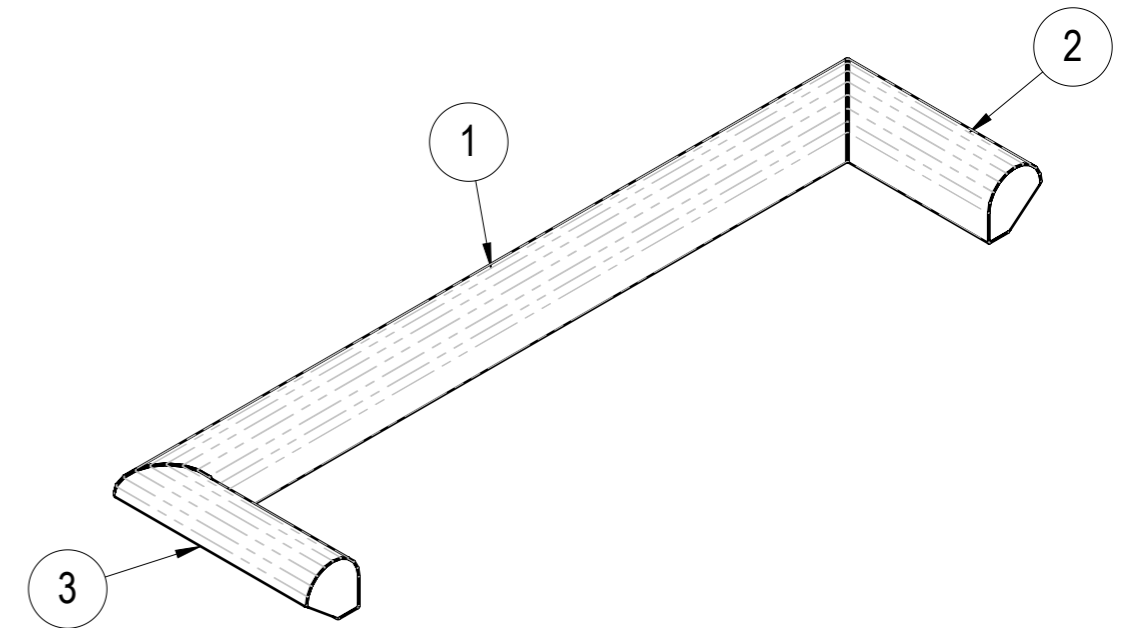
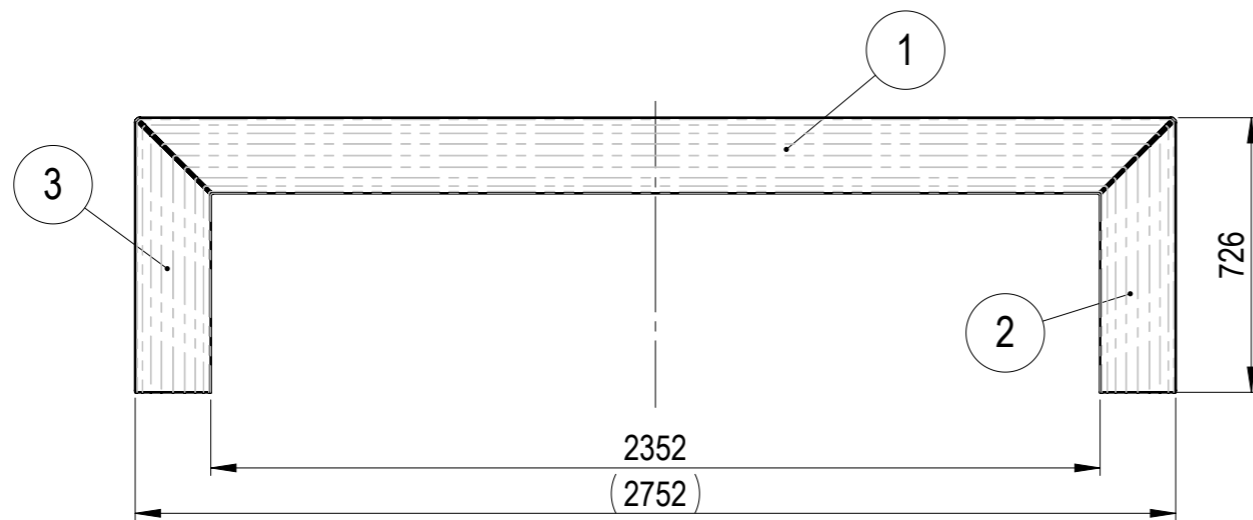
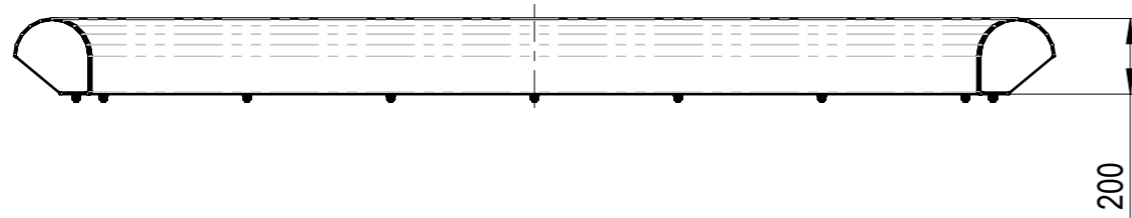
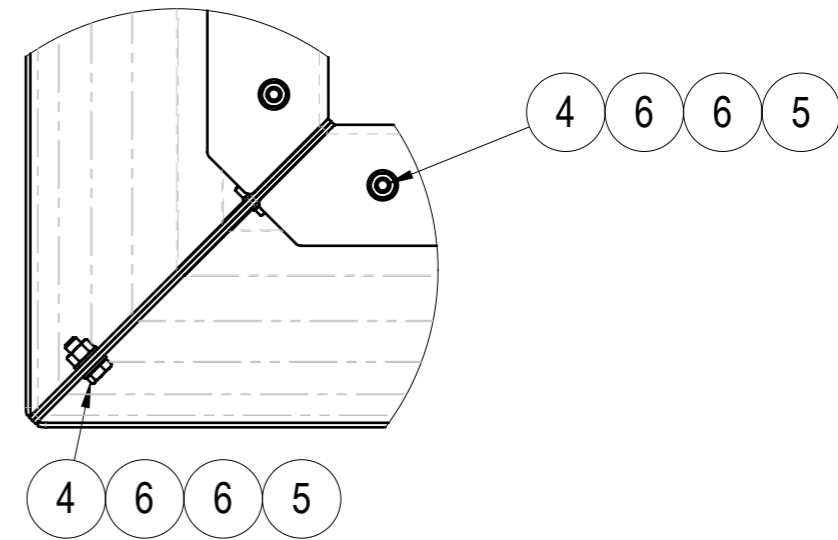

NO.	PART NO	DESCRIPTION	MATERIAL	PROCESSING	REVISION	WEIGHT	QTY
1	105-30301-00	Middle section	-	WLD HDG		31.13	1
2	105-30302-00	Side section R	-	WLD HDG		8.22	1
3	105-30303-00	Side section L	-	WLD HDG		8.22	1
4	ISO4017 (DIN933) M10x25	Hex bolt	HDG-8.8	COTS		0.03	15
5	ISO4032 (DIN934) M10	Hex nut	HDG-8	COTS		0.01	15
6	ISO7089 (DIN125) M10	Plain Washer	HDG-HV200	COTS		0.00	30

WEMPS
ENGINEERING SERVICES

MATERIAL	WEIGHT	DEBURR AND BREAK SHARP EDGES	REVISION	DATE
-	48.231 Kg	DO NOT SCALE DRAWING		13.05.2025
SURFACE PROTECTION	MACHINING	THERMAL CUTTING	WELDING	SCALE
-	ISO 2768 mK	ISO 9013 441	ISO 13920 BF	1:20
				FORMAT
				A3

NAME	SIGNATURE	PART NO.	105-30300-00	
Designed by	E. Lagzdins			
Drawn by	E. Kriviss	DESCRIPTION		
Technical ref.		Inlet fairing		
				SHEET 1/1